

R1100 and R2300

Installation and User Manual



Advanced Battery Chargers

Table of Contents

R1100 and R2300.....	2
General.....	2
Installation and Warnings.....	3
Operations.....	5
Lights and push buttons.....	6
Safety Instructions.....	8
Trouble-shooting and repair.....	9
Guarantee.....	9
Editing charging configuration.....	9
Connectors and pin orders:.....	11
Algorithms.....	12
Charger dimensions.....	15

R1100 and R2300

Powerfinn Robust series chargers uses modern switching technology. The intelligent microcontroller extends the life of the battery by supervising the charging process. The charger are compact, silent and meets the EU safety and EMC requirements.

Protection class against water & dirt is IP54.

General

Chargers are available for a variety of battery types.

The charger type and charging algorithm should correspond to the battery (sealed, vented, etc.). Attempting to charge a battery with the wrong type of charger may result in considerable damage.

Find "Editing charging configuration paragraph" and "Operations".

Check the battery to ascertain that the "five hour capacity" (in ampere-hours, Ah₅ or Ah@5h) is between 5 and 14 times greater than the nominal current (in amperes) of the charger. E.g. a 10A charger is suitable for charging batteries with a 5-hour capacity of 50Ah-140Ah.

Installation and Warnings

The following points must be respected when choosing a location for the charger.

1. In fixed installation the operation temperature range is -35°C to $+55^{\circ}$. Higher than $+40^{\circ}$ ambient temperature will limit the output power.
Caution: Mains cord & battery cable "indoor use" min temperature $+5^{\circ}\text{C}$. Do not bend in cold environment.
2. The charger is to be installed vertically on a concrete or other non-combustible surface only. For unplugging the unit, make sure the wall socket is located in an easy access area.
3. To ensure sufficient ventilation, leave a free space of at least 10 cm around all sides and 30 cm top and bottom of the charger. Do not cover the unit.
4. The charging process generates explosive hydrogen gas. Install the charger as far away from the battery as possible to prevent hydrogen gases from entering the charger. Keep the area well ventilated. Never use an open flame or equipment that produces sparks close to the battery and charger.
5. Charger is to be installed vertically to a wall like shown in the next figures

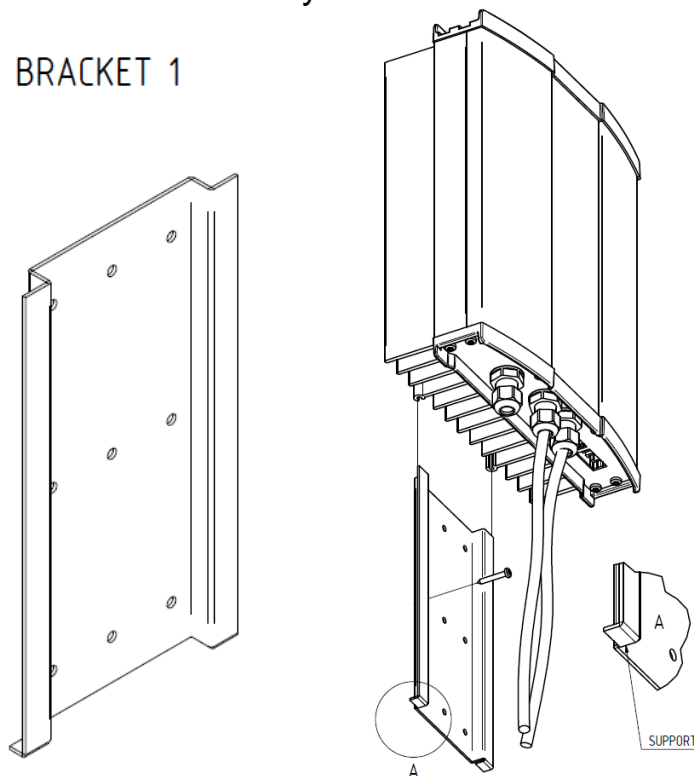

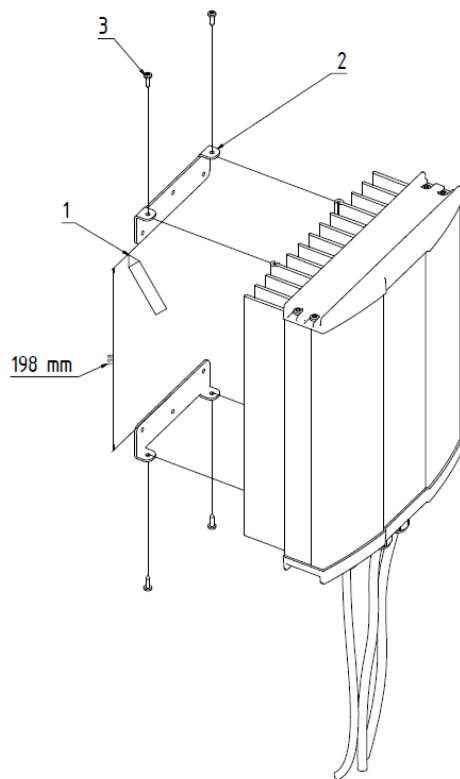
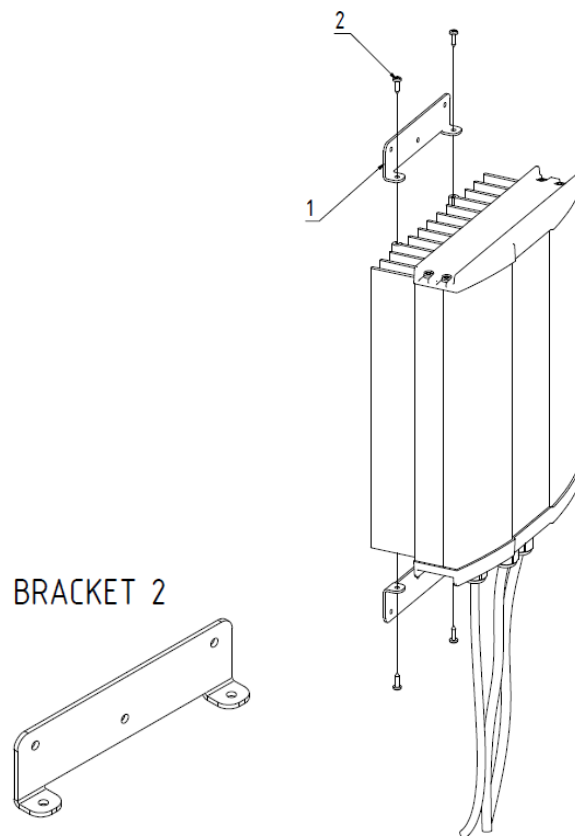

Operations

Read these operating instructions carefully before using the charger for the first time. Also read the safety instructions in the next paragraph thoroughly.

It must be ensured that children do not play with the device.

To charge a battery with "Robust series" charger, follow these instructions:

Charger is configured with factory default settings. The factory default setting is 12 cells algorithm LK10-06 freely ventilated, capacity 50 Ah. Find "Editing charging configuration paragraph page 8".

1. Ensure that the charger is unplugged and that the installation environment meets the conditions described in the previous paragraph.

Warning: Explosive gases. Prevent flames and sparks. Provide adequate ventilation during charging.

2. Connect the charger cables to the battery terminals: the positive (+) cable to the positive (+) terminal and the negative (-) cable to the negative (-) terminal. The positive cable is red colored. The negative cable is black or blue.

3. Turn the power on by plugging the power cord in a mains outlet with protective earth.

4. Charging starts automatically.

STOP

Pressing STOP will **PAUSE** charging. Pressing STOP again resumes charging.

F1 and F2

F1 and F2 buttons can be assigned the various functionality. By default no function is assigned. Pressing buttons while charging process does not have any effect to charging. Buttons are used when battery settings will be programmed. More details in section "Editing charging configuration".

5. To avoid sparking in output cables, press STOP button before disconnecting battery.

Lights and push buttons

Chargers front label should look following.

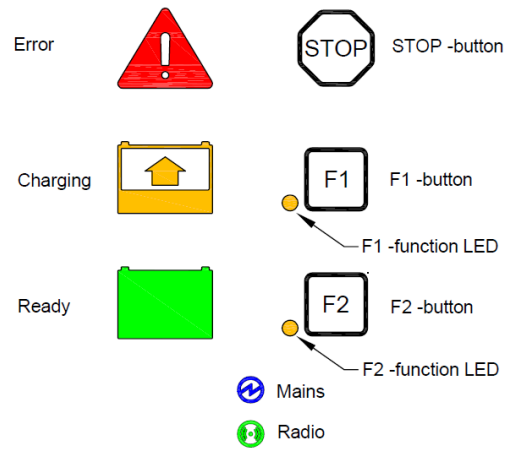

Main is connected.













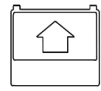
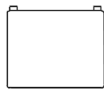

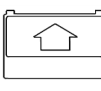
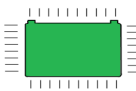

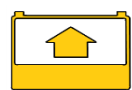
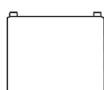

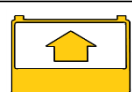

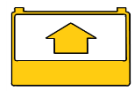
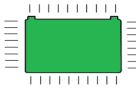

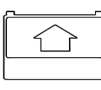

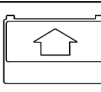
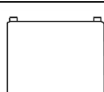

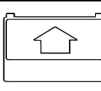

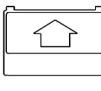
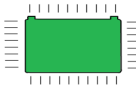

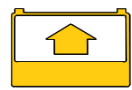
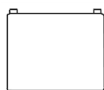
Radio module is ON.

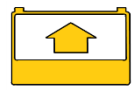
Charger can be assembled with optional radio module. Module allows access to configuration and history log of the charger.

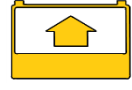
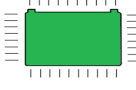
Light symbol definitions:

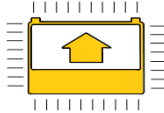
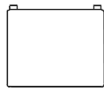
	Error	Charging	Ready
No light			
Continuous light			
Flashing			

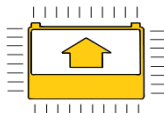
1. Light alternatives and meaning:

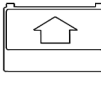
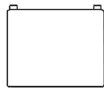
			None of indicators are lit: Charger is waiting for a battery connection. Only small blue led lights continuously.
			Green flashing: STOP pressed, charging paused.
			Yellow continuously lit: main charging phase. Defined in charging algorithm.
			Additional charging. Defined in charging algorithm.
			Equalize charging. Defined in charging algorithm.
			Charging ready, maintenance charging. Defined in charging algorithm.
			Alarm, no specific.
			Alarm, low battery voltage. Defined in charging algorithm.
			Alarm, high battery voltage. Defined in charging algorithm.
			Alarm, time limit exceeded. Defined in charging algorithm.
			Alarm, Ah limit exceeded. Defined in charging algorithm.
			Alarm, invalid charging parameters.
			Alarm, high charger temperature.
			Alarm, low charger temperature or sensor fault.
			Alarm, regulation fault.

Safety Instructions

In addition to the safety measures mentioned under 'Operations' (page 5), the following personal precautions should be taken whenever charging batteries.

1. For emergency situations ensure in advance that help is available in time of need.
2. Batteries contain acid that is harmful to the eyes, skin and clothes. Always wear overalls and safety goggles. Never touch the eyes with unwashed hands after handling batteries.
3. Ensure that a working, fresh water tap is available. If acid gets into the eyes or on the skin, immediately rinse the area with plenty of water for several minutes. If visible injury occurs, contact a physician immediately. In case of eye injuries, always contact a physician.
4. The charging process generates explosive hydrogen gas. Do not smoke or otherwise bring burning or sparking matter to the vicinity of the battery when it is being charged.
5. If a short circuit occurs, the battery may explode or the item causing the short circuit may melt. Keep the work area clear from tools and debris. Remove jewelry, watches etcetera before working with the battery.
6. The power cord should be unplugged and the battery must be disconnected from the charger in case the equipment is left unused for a longer period of time.
7. The charger must locate away from heat sources like radiators and heat registers.
8. This device is not meant to be used by children or people whose physical, sensory or mental attributes or lack of experience and knowledge prevent them from using the device safely unless a person responsible for their safety supervises them or has instructed them how to use the device.

Trouble–shooting and repair

If the cause of malfunction cannot be found, contact your retailer or the manufacturer. Only authorized persons can repair the charger.

Guarantee

The charger has a guarantee of two years from the date of purchase. Guarantee covers manufacturing and component failures and is valid only if the equipment is installed and used according to the instructions in this manual.

Keep the receipt as evidence of the date of purchase.





Editing charging configuration

1. Disconnect battery.
2. Connect mains power.
3. As soon as blue LED is lit, press STOP for 10 s. LED's should flash shortly. Release STOP. Special configuration mode has been entered.
4. To scroll down the list, press STOP.
5. To set item on/off, press F1. List of items are in table below.



6. After configuration has been set, disconnect mains power.

Following table equals with program version 11613002v02. Check the program version from the charger labels! Bold text in coloured areas indicates LED "ON".

	 Red/ Error	 Yellow/ Charging	 Green/ Ready	 Blue/ Mains	 small green/ Radio	item
1	red	yellow	green	blue	s.green	algorithm LK10-06 freely ventilated
2	red	yellow	green	blue	s.green	algorithm LK10-04 wet puls
3	red	yellow	green	blue	s.green	algorithm LK20-09 valve ventilated Sonnenschein
4	red	yellow	green	blue	s.green	algorithm LK10-05 wet with constant current maintenance charging
5	red	yellow	green	blue	s.green	algorithm PP100 unsealed
6	red	yellow	green	blue	s.green	algorithm PP101 sealed
7	red	yellow	green	blue	s.green	algorithm PP102 Sonnenschein
8	red	yellow	green	blue	s.green	algorithm --
9	red	yellow	green	blue	s.green	capacity 50 Ah
10	red	yellow	green	blue	s.green	capacity 75 Ah
11	red	yellow	green	blue	s.green	capacity 100 Ah
12	red	yellow	green	blue	s.green	capacity 125 Ah
13	red	yellow	green	blue	s.green	capacity 150 Ah
14	red	yellow	green	blue	s.green	capacity 200 Ah
15	red	yellow	green	blue	s.green	capacity 250 Ah
16	red	yellow	green	blue	s.green	capacity 300 Ah
17	red	yellow	green	blue	s.green	capacity 350 Ah
18	red	yellow	green	blue	s.green	capacity 400 Ah
19	red	yellow	green	blue	s.green	capacity 450 Ah
20	red	yellow	green	blue	s.green	capacity 500 Ah
21	red	yellow	green	blue	s.green	capacity 550 Ah
22	red	yellow	green	blue	s.green	capacity 600 Ah
23	red	yellow	green	blue	s.green	capacity 700 Ah
24	red	yellow	green	blue	s.green	capacity 800 Ah
25	red	yellow	green	blue	s.green	Operation mode ●-Charger ●-Power supply
26	red	yellow	green	blue	s.green	External input ●-Not Active ●-Stop
27	red	yellow	green	blue	s.green	CAN-mode ●-Master ●-Master ext
28	red	yellow	green	blue	s.green	Reserved (Parallel operation)
29	red	yellow	green	blue	s.green	Reserved (BMU-unit control)
30	red	yellow	green	blue	s.green	Reserved

Connectors and pin orders:

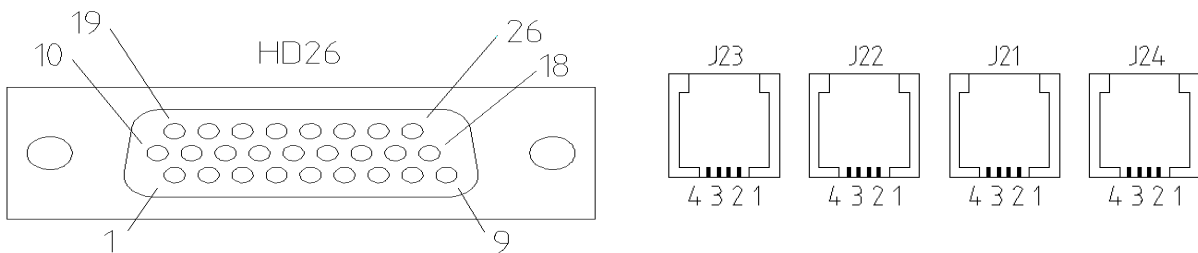
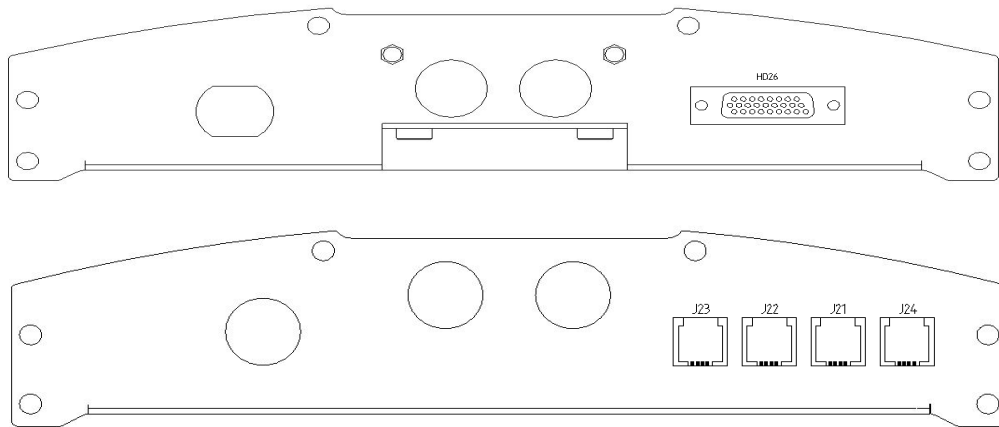

J-Connectors and pin numbers	J-connector cable wire colors	HD26 Connector's pin order	Operation
J23-1	black	4	LED green anode (10mA current source)
J23-2	red	22	LED common cathode (Same ground as is in battery minus)
J23-3	green	14	LED red anode (10mA current source)
J23-4	yellow	5	LED yellow anode (10mA current source)
J22-1	black	2	Sense plus (+)
J22-2	red	12	Battery temperature compensation (-) (Sensor: 2 series connected Philips KTY83-120 sensors)
J22-3	green	3	Battery temperature compensation (+)
J22-4	yellow	20	Sense minus (-)
J21-1	black	19	External digital input (+) (Signal send when shor-circuited between HD26 pin 11.
J21-2	red	1	CAN-bus Hi
J21-3	green	10	CAN-bus Lo
J21-4	yellow	11	External input (-)
J24-1	black	26	Relay Common (0.5A@125Vac , 2A@30VDC , 0.3A@110VDC)
J24-2	red	18	Relay Normally Open
J24-3	green	9	Relay Normally Closed
J24-4	yellow		Not connected
		25	Isolated +5V, 5mA output
		7	Isolated output ground (Same grounds as in HD26 pin 11)

Algorithms

LK10-06 freely ventilated (Temperature sensor supported)

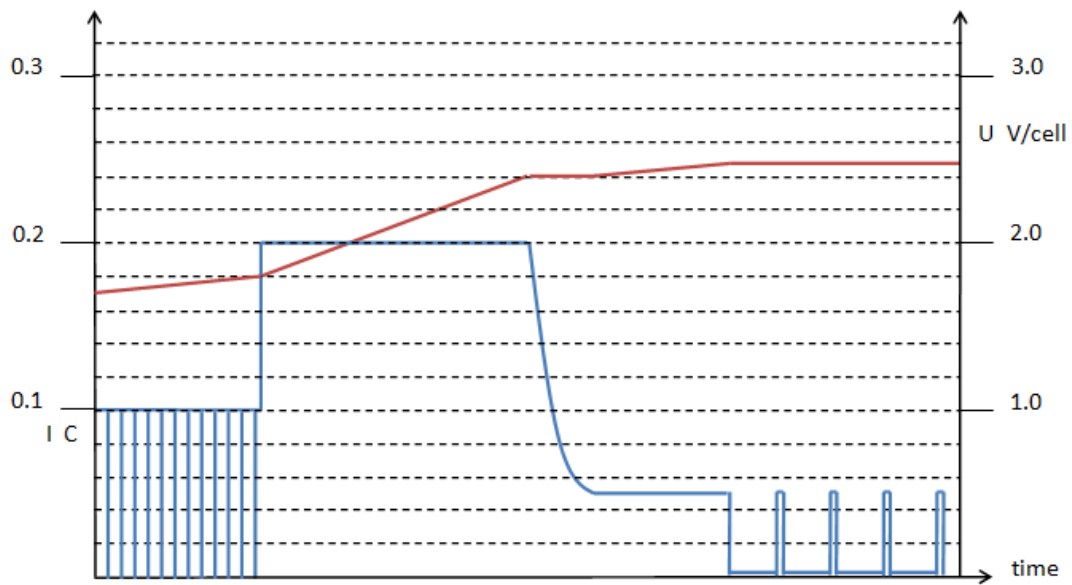

LK10-04 wet puls (Temperature sensor supported)

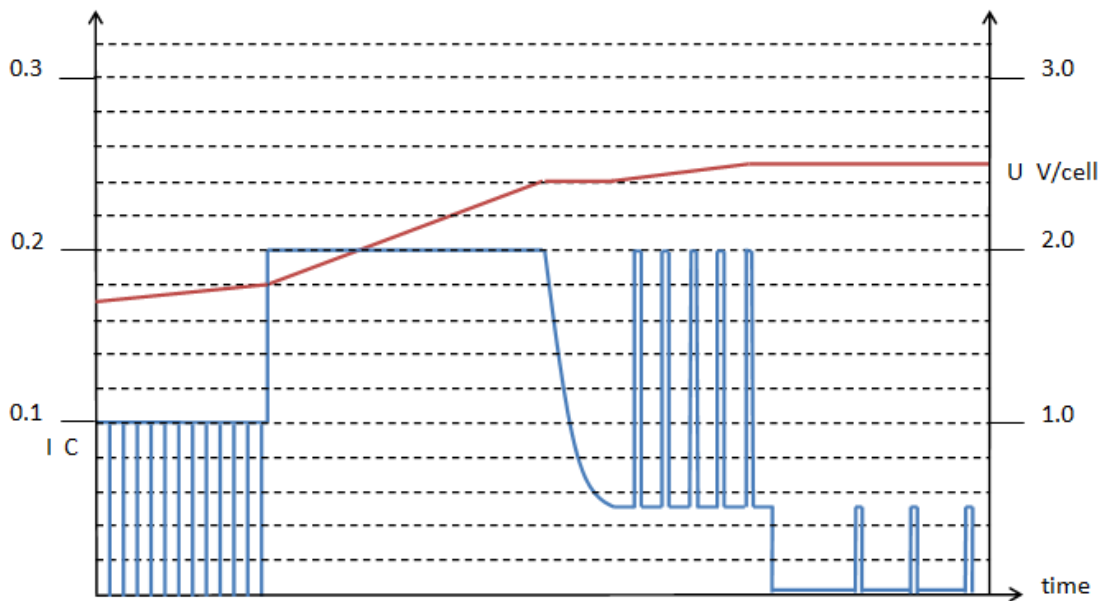

LK20-09 valve ventilated Sonnenschein (Temperature sensor not supported)

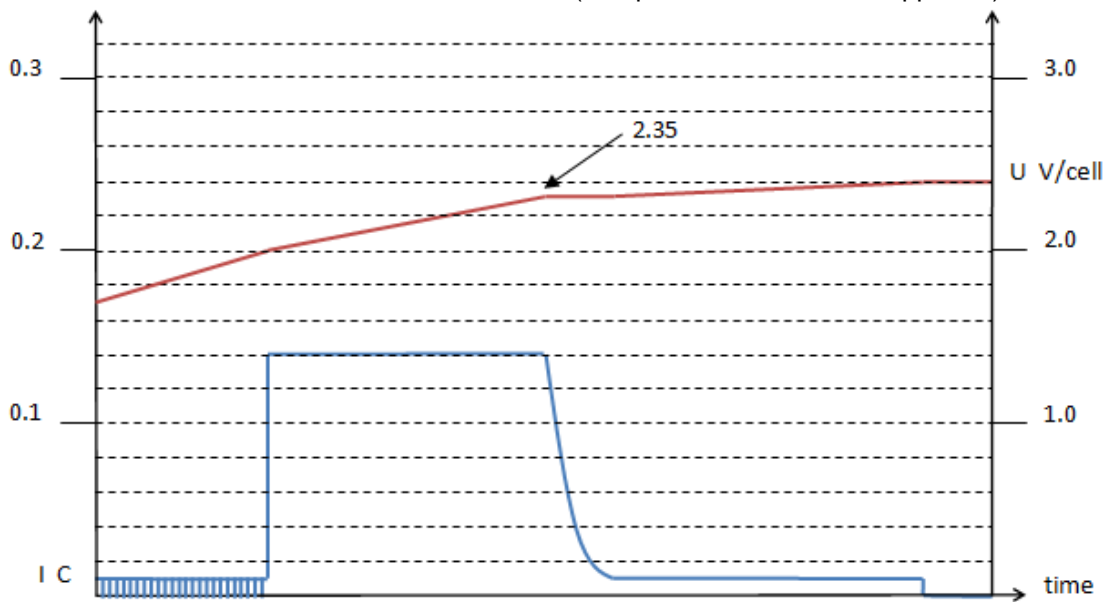

LK10-05 wet with constant current maintenance charging (Temperature sensor supported)

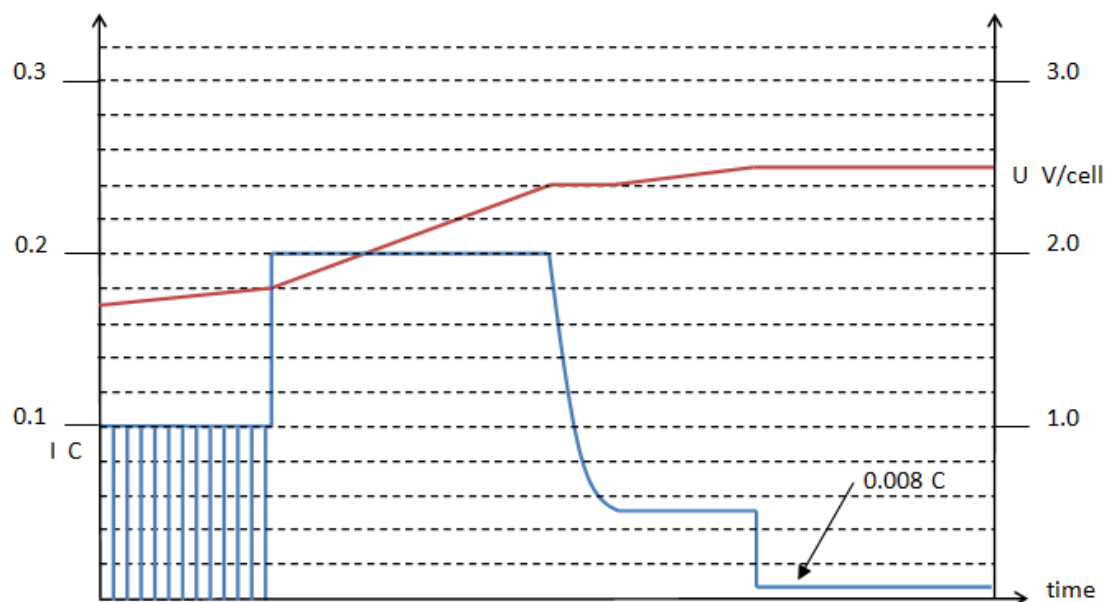

PP100 unsealed (Temperature sensor supported)

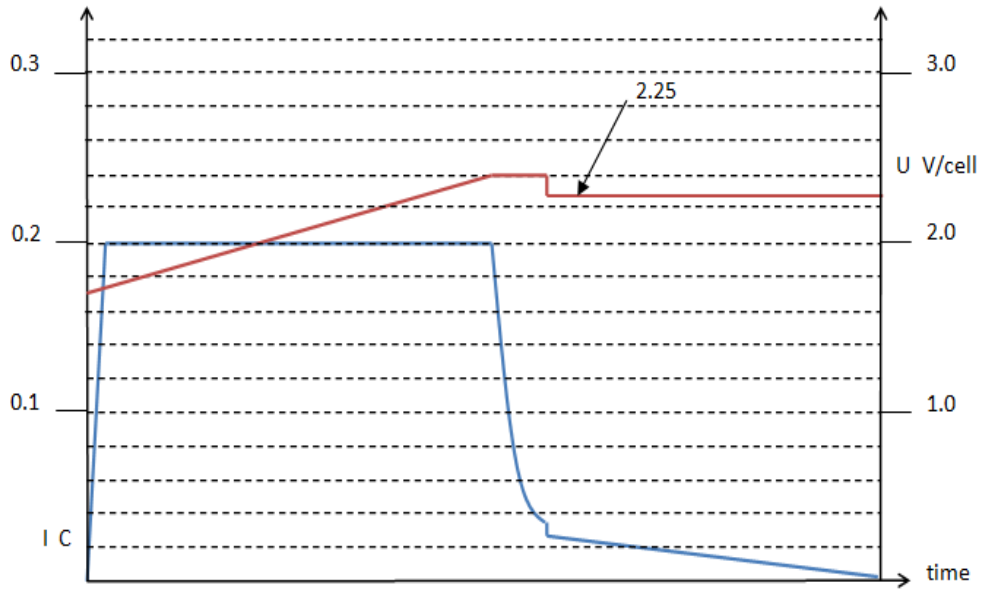

PP101 sealed (Temperature sensor supported)

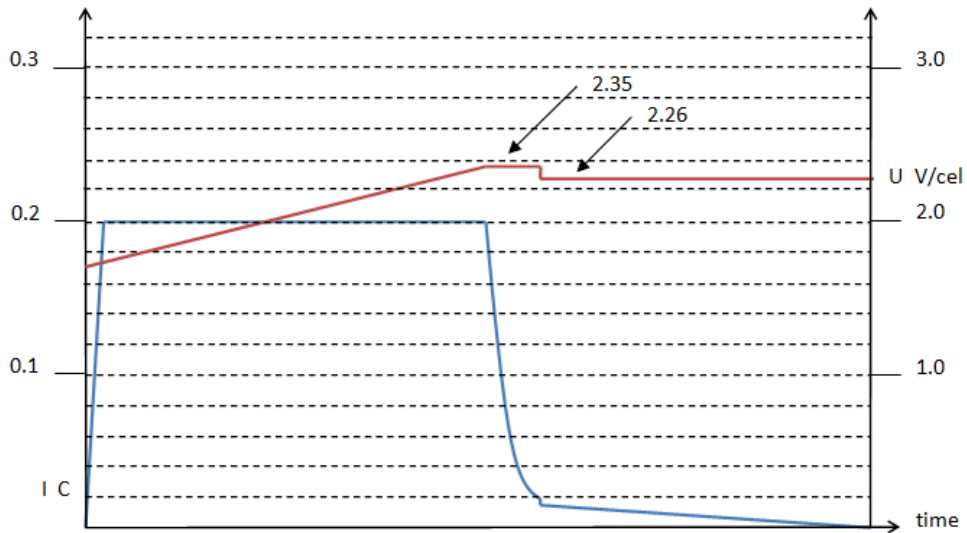

PP102 Sonnenschein (Temperature sensor supported)

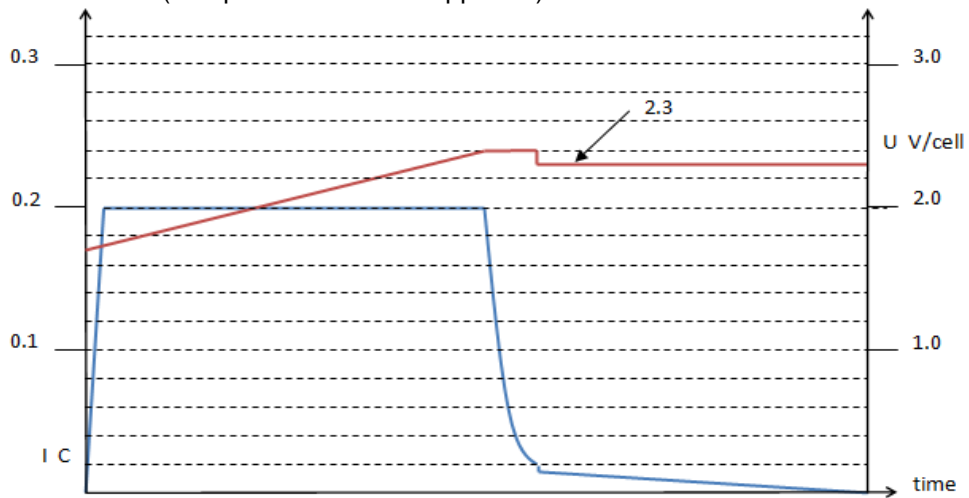

Charger dimensions

Dimension drawing for R2300 which is always fan installed.

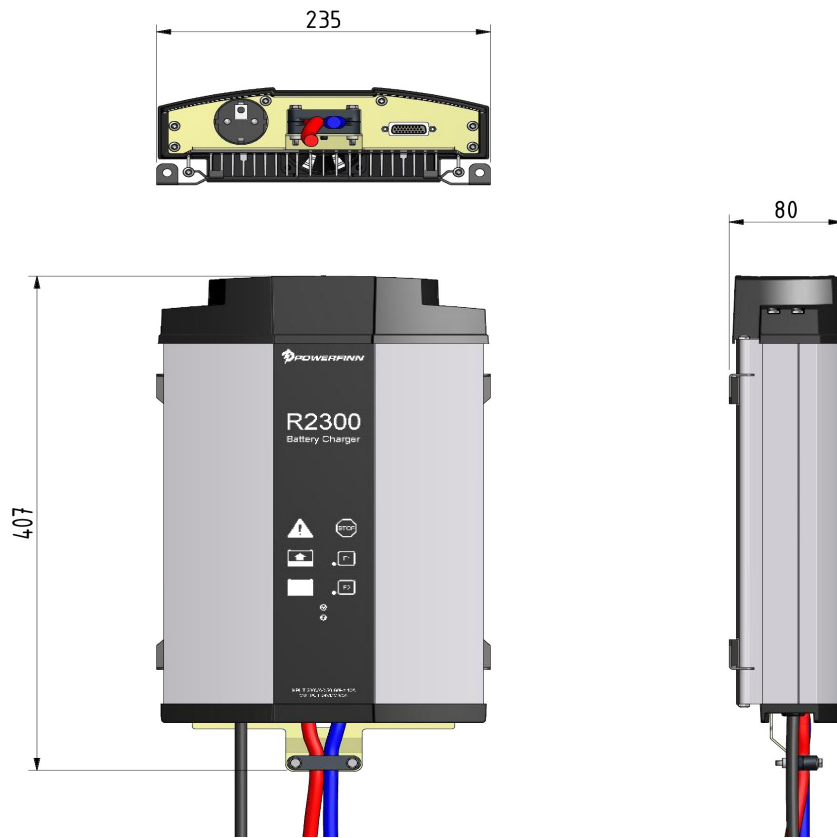

Dimension drawings for R1100 with fan and R1100 without fan.

