

ECOFLOW

User Guide

RIVER

PORTABLE POWER STATION

Extra Battery



Contact us:
support@ecoflow.com
www.ecoflow.com



1. Please keep the product dry, do not expose it to high heat. Pay attention to the safety when carrying the product.
2. Never disassemble, puncture, shock, crash, or incinerate the product or the accessories.
3. After removing the package, the Max Module must be installed with RIVER 600 in time. Please pay attention to static electricity during the installation process.
4. Recycle and dispose of RIVER 600 in accordance with local regulation.
5. People with disabilities or children should use the machine under the protection of the supervisor.

Glossary

The following terms are used in this document to indicate various levels of potential harm that may be caused by improper operation.

NOTICE

The instructions, if not properly followed, may result in property damage and minor physical damage.

CAUTION

The instructions, if not properly followed, may result in property damage and serious physical damage.

Warning

The instructions, if not properly followed, may result in property damage, major accident and serious injury.

WARNING

Read the ENTIRE user manual to be familiar with the features of this product before operating. Failure to operate the product correctly may result in damage to the product or personal property and cause serious injury. EcoFlow will not assume any legal responsibility. DO NOT use the product with incompatible components or alter the product in any way without following the instructions provided by EcoFlow. Otherwise, you cannot get after-sales service from EcoFlow under warranty condition. These Safety Guidelines include instructions for safety, operation and maintenance. It is important to read and follow all the instructions and warnings in the user manual before assembly, setup or use the product.

Product Safety Guidelines

WARNING

Improper use may result in fire, property damage or personal injury. Make sure to use the product according to the following safety rules and guidelines.

Installation Notes:

1. The Extra Battery Module must be installed with RIVER 600 before it can be used. It cannot be used alone.
2. During the install process, you must pay attention to anti-static protection to ensure that there is no static electricity on the human body and around. Static electricity may cause damage to the product.
3. RIVER 600 must be turned off before the install process.
4. The screws must be tightened to ensure the RIVER 600 is locked with the extra battery module.

Product Use:

1. DO NOT expose the product to any liquids. Do not immerse the product in water. DO NOT leave the batteries out in the rain or near a source of moisture. Moisture in the device could cause short circuits, component failure, fires or even an explosion.
2. Never use NON- EcoFlow part. Go to <http://www.EcoFlow.com> to purchase new parts. EcoFlow takes no responsibility for any damage caused by the use of non-EcoFlow parts.
3. Never install or remove other modules from the RIVER 600 when it is turned on. Do not plug or unplug other modules when the power of the product is turned on, otherwise the power interface may be damaged.
4. The product should be used in temperatures between -4°F and 140°F(-20°C and 60°C). The use of product in environments above 140 °F(60°C) may cause fire or explosion. Using product below -4°F(-20°C) will severely affect the performance of the product. Allow the product to return to a normal operating temperature before use it.
5. DO NOT use the batteries in strong electrostatic or electromagnetic environments. Otherwise, the battery control board may malfunction and cause a serious accident during use.
6. Never disassemble or pierce the product in any way. Otherwise, it may leak, catch on fire, or explode.
7. DO NOT use the product if it was involved in a crash or a heavy bump.
8. If the product falls into the water during use, take the product out immediately and put it in a safe and open area. Keep a safe distance from it until it is completely dry. Never use it again and dispose it properly as described in the Battery Disposal section below. If the product catches fire, it is recommended to use fire extinguishing equipment in the following order: water or water mist, sand, fire blanket, dry powder, carbon dioxide fire extinguisher.
9. DO NOT put the machine in a microwave oven or in a pressurized container.
10. Do not allow pins, wires or other metal pieces to insert to the device case, outlets or controls. Metal pieces may short circuit the product.
11. Avoid collision. DO NOT place heavy objects on the machine.
12. If there is dirt on any plug or outlet surface, use a dry cloth to clean it. Otherwise, it will cause abrasion and result in energy loss or inability to charge.

Product Charging

1. Always use EcoFlow approved charge cables. EcoFlow does not response to any damage caused by using non-EcoFlow charging cable.
2. When charging, please place the product on the ground with no flammable or combustible materials around. To prevent accidents, never leave the battery unattended during charging.
3. DO NOT charge a product immediately after a long heavy load, because the product's temperature may be too high. DO NOT charge a product until it cools down to room temperature. The battery may be unable to charge out of a temperature outside the range of 32°F to 104°F (0 to 40°C). The ideal charging temperature range is 71°F to 82°F(22 to 28°C).

Product Storage and Transportation:

1. Keep the product out of the reach of children. If any children accidentally swallow parts, please go to a doctor immediately.
2. If a low-battery warning appears, charge the battery before store it. Otherwise, long-term storage may cause damage to the battery. Batteries in the product will enter hibernation mode if it depleted and stored for a long time. Recharge the product can bring the battery out of hibernation.
3. DO NOT place the product near a heat source, such as a car in direct sunlight, a fire source, or a heating stove.
4. Store the product in dry environments. DO NOT place the product where it may contact with water.
5. Make sure no small metal objects can fall on or around the product while in storage.
6. Never transport a product with a battery power level higher than 30%.

Product Battery Disposal:

1. Dispose the product in specific recycling boxes only after a complete discharge. Batteries are hazardous chemicals. Please strictly follow your local regulations regarding the battery disposal and recycle.
2. Dispose of the product immediately if it cannot be powered on after over-discharging.

Product Maintenance:

1. Never store the product in environments below -4°F (-20°C) or above 140°F (60°C).
2. If the battery is not used for a long time, the battery life may be reduced.
3. Fully charge and discharge the battery at least once every 3 months to keep the battery healthy.

Travel Notice:

It is forbidden to carry lithium batteries and equipment with a capacity greater than 160Wh on airplane due to the regulation; Do not bring this product on flights.

CONTENTS

RIVER 600 Extra Battery Use Care and Safety Guide -----	1
RIVER 600 Extra Battery Module Installation Instructions -----	2
Ambient Light Area -----	6
Technical Specifications-----	7
What's in the Box -----	7

RIVER 600 Extra Battery Module Use Care and Safety Guide

CONGRATULATIONS!

You now own the best quality portable power station Extra Battery in the world. This pamphlet is meant to help you. Please take some time to read it and install the Extra Battery Module according to the instructions on the manual. You can fully understand how to use the Extra Battery Module and increase the experience of using Portable Lithium Generator!

NOTICE

Make sure to turn off the RIVER 600 before install the expansion battery. You need to press and hold the ON/OFF power button to ensure that the power is off. You must not turn the RIVER 600 on before installing the bottom cover to avoid the poor battery contact. After the installation is complete, restart the product, and enjoy the high capacity experience brings by the RIVER 600. Please don't remove the battery often, otherwise, the product will repeatedly perform the cell balancing function, which will affect the user experience. After using the RIVER 600 for a long time, purchase and install the expansion battery pack, the output will be affected by the inconsistency of the balance between the new and old batteries, and the user experience could decline, it is normal, which is recommended to buy RIVER 600 and battery pack at the same time. (Before any further reading and operation, please charge the product to 100%!)

RIVER 600 Extra Battery Module Installation Instructions

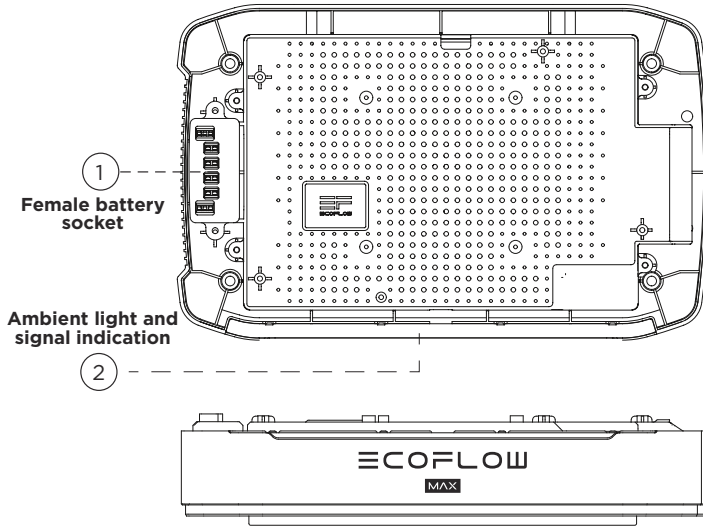

1. Female Battery Socket And Installation Instructions

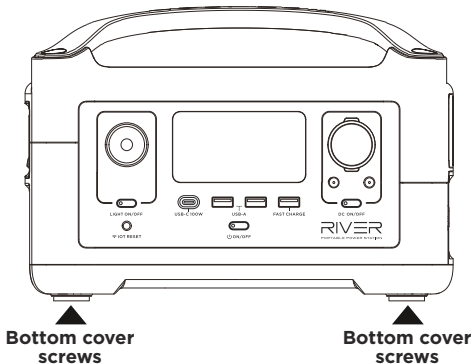

1. Please make sure that the RIVER 600 is turned off. Take out the screwdriver from the extra battery module kit and locate the four screws on the bottom cover.

Note: Please pay attention to prevent static electricity during the installation process.

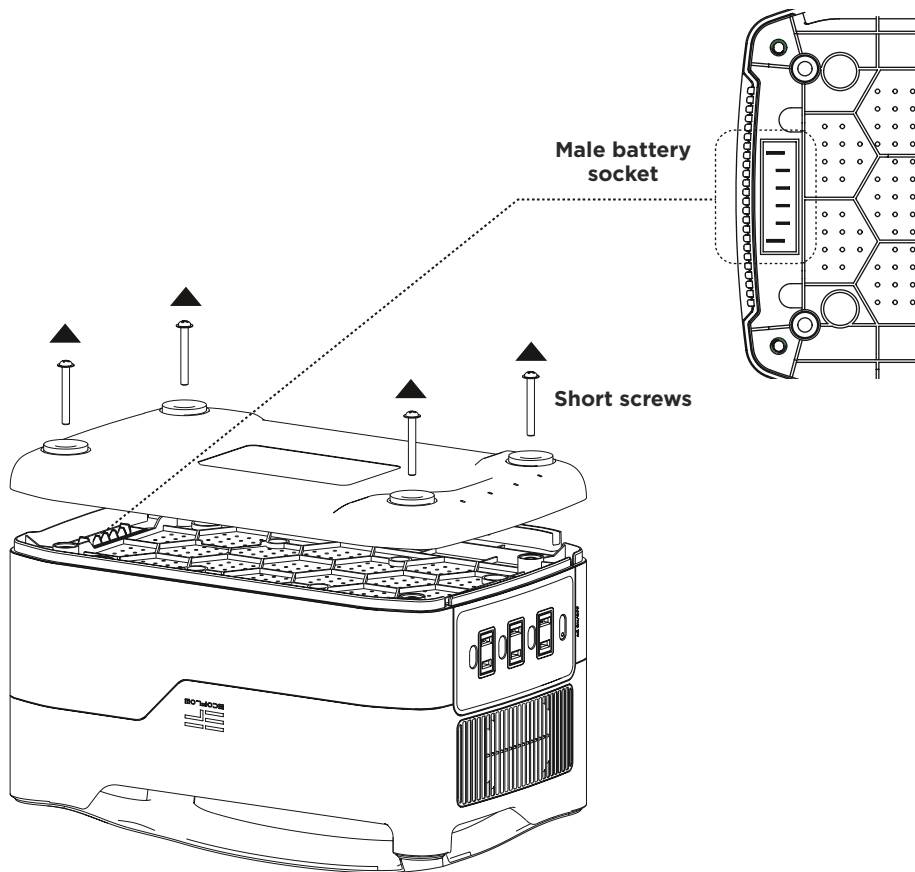

2. Please unscrew the 4 screws according to the figure and remove the bottom cover. You can see the male battery socket. The extra battery module should be positioned as shown in the figure. (Please note that only the bottom cover needs to be remove. Do not remove the top cover.)

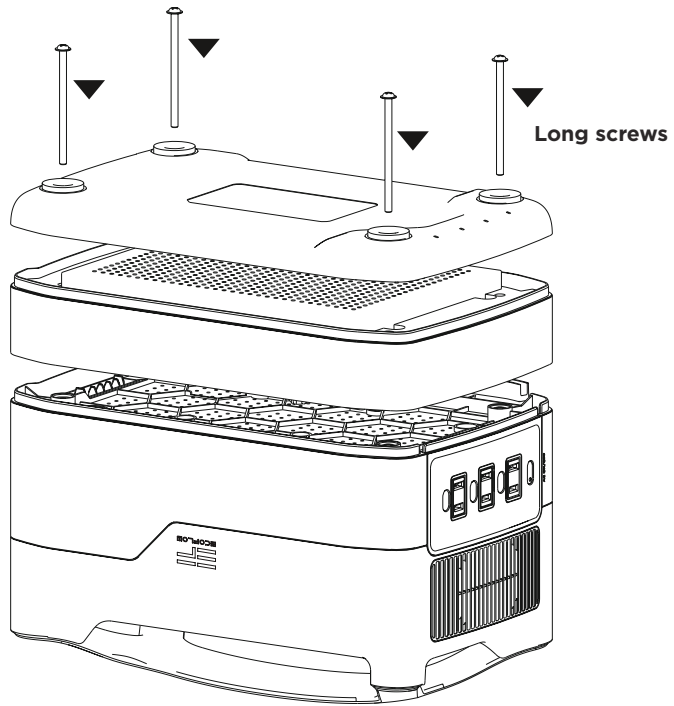

3. Align the male and female battery sockets and connect them. Close the bottom cover. Take the four long screws from the kit and screw them on the screw mouth.

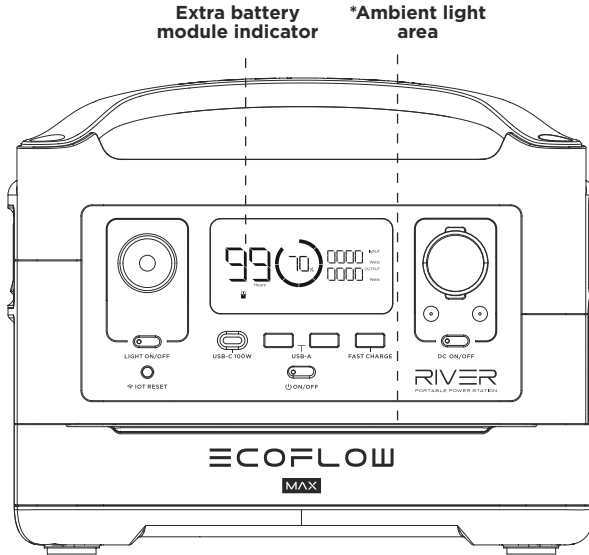

4. Put the RIVER 600 upright and turn it on. The extra battery module's ambient light will turn blue. If the extra battery module indicator light is shown on the RIVER 600's display, the extra battery module is activated successfully. Please make sure the machine is fully charged before use. If the ambient light or the extra battery module indicator light is not active, repeat Step 2 then check the connection.

*Ambient Light Area

1. Status Signals



Powering up: The blue light will move from the middle to the sides



Powering down: The blue light will move from the sides to the middle.



Charging: The blue light will move from left to right repeatedly.

2. Customizing the Ambient Light

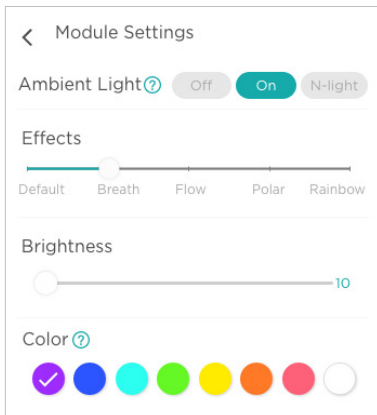

Click the Module Settings to set various functions.

1. You can set up to turn on/off the ambient light or keep the light always on (the ambient light can also be on in standby mode).
2. You can select the color you prefer.
3. You can adjust the brightness of the light.
4. You can also set the lighting mode. There are default mode, breathing mode, flow mode, dynamic mode and rainbow mode. Feel free to choose the color you like and enjoy the fun brought by the ambient light.

Technical Specifications

General Specs

Net Weight	* 5.5lbs (2.5kg)
Dimensions	* 11.2 x 7 x 2.3in (28.5 x 18 x 5.9cm)
Capacity	288Wh (28.8V)
Testing and certification	UL Standard, CE, FCC, RoHS

Battery

Cell Chemistry	Lithium-ion
Discharge Temperature	-4 to 140°F +/-5°F(-20 to 60°C +/-3°C)
Charge Temperature	32 to 113°F +/-5°F(0 to 45°C +/-3°C)
Shelf Life	1 Year (after fully charged)
Cycle Life	500 Cycles (80%)

*Please Note: The above weight, size, etc. have certain measurement errors. Please refer to the actual measurement.

What's in the Box

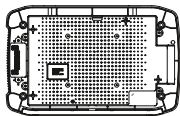

**Extra Battery
Module**

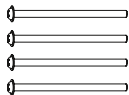

4 Long Screws

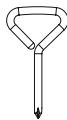

Cross Screw Driver



**User Manual and
Warranty Card**